

NOTA: USINAR EIXO PARA AJUSTE DESLIZANTE
 NOTE: SHAFT DIAMETER TOLERANCE: SLIDING FIT

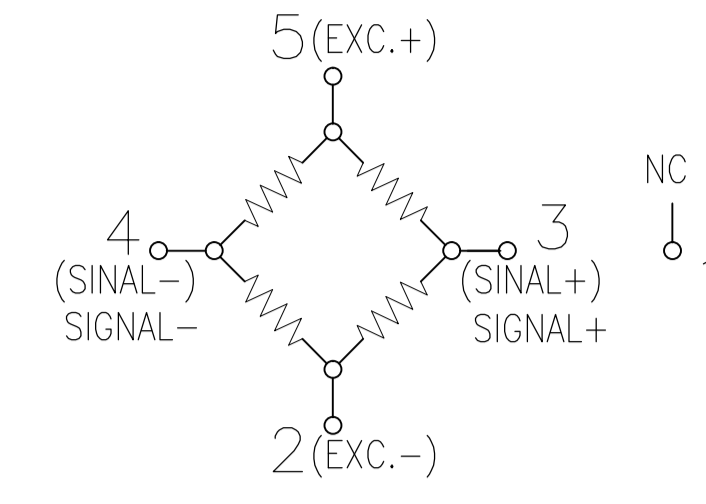
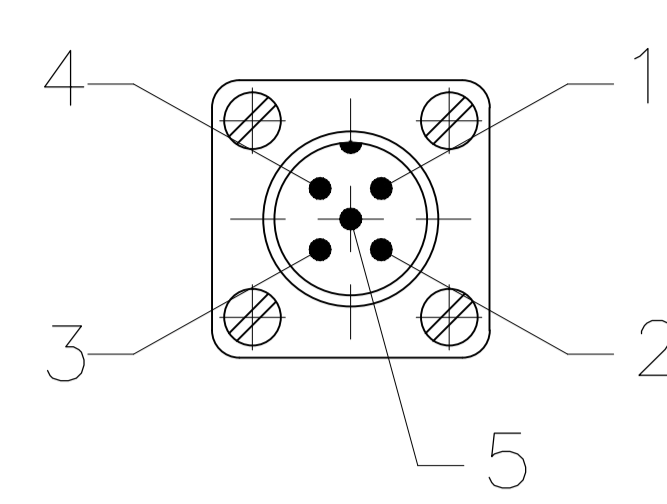

CAPACIDADE NOMINAL
 CAPACIDAD NOMINAL
 NOMINAL CAPACITY

| MOD. | kgf |
|--------|-----|
| PML-25 | 25 |
| PML-50 | 50 |
| PML-75 | 75 |

PRESTMAC
 automação industrial
 WWW.PRESTMAC.COM.BR

CÉLULA DE CARGA
 CELDA DE CARGA
 LOAD CELL

PML



PRESTMAC
 automação industrial
 WWW.PRESTMAC.COM.BR

CÉLULA DE CARGA
 CELDA DE CARGA
 LOAD CELL

PML